



---

# **Using the TB8100 Base Station as a Talk-Through, Community, or Linked Repeater**

---

**Application Note TN-743**

**1 June 2003**

**Tait Electronics Ltd**

558 Wairakei Rd, P.O. Box 1645, Christchurch, New Zealand

Phone: +64 3 358 3399 Fax: +64 3 358 6486

[www.taitworld.com](http://www.taitworld.com)

Page 1 of 8

This Application Note gives guidance on how to configure a Tait TB8100 base station as a standalone repeater. It also describes the additional changes needed to configure a TB8100 as a community repeater or to use TB8100 equipment to build a linked repeater. For more detail or answers to specific questions, consult the documentation for the TB8100 base station and service kit or contact your dealer or nearest Tait office.

## Standalone Talk-Through Repeater

Standalone repeaters receive on frequency F1, pass the audio from the receiver to the transmitter, and re-transmit the audio on F2.

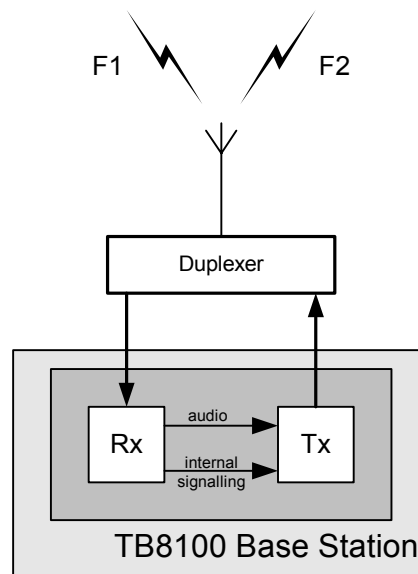

**Figure 1 Standalone Repeater**

A TB8100 base station does not need a system interface card to be a repeater, as the audio path from receiver to exciter occurs within the reciter module and is configured in software.

The repeater can be provided with a radio modem or a telephone line and a dialup modem for remote configuration and monitoring. See TN-742 *Remotely Monitoring and Configuring the TB8100 Base Station* for more information.

Configuring the base station is done using the TB8100 service kit. Pay particular attention to the following:

- Configure the signal path to connect the receiver audio to the transmitter. For example, in the Talk through repeater list, click A-A.

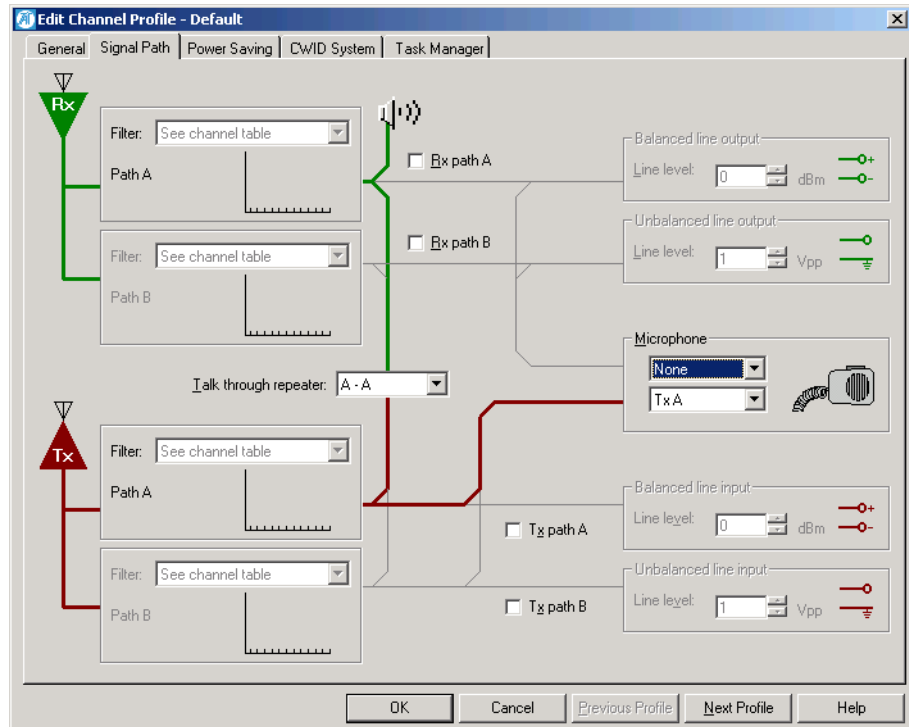

- In the General tab of the Edit Channel Profile dialog box for the channel profile that is assigned to the default channel, define the talk-through repeater gain. If you are unsure what value to use, enter 0 dB.
- If the repeater uses solar power, enable and configure power saving in the Signalling Profile, Power Saving tab. (This requires a Power Saving Modes license.)
- In the channel table, configure the audio filtering and subaudible signalling to suit your system and application requirements.

Channel Table									
	Num	Channel Name	Signalling Profile	Receive Signalling	Transmit Signalling	Channel Profile	Filter	Power (W)	Channel Spacing
	001	Main channel	Default	C 67.0 Hz	Same as rec	Default	Flat Speech Band	50	12.5

- Make any other channel configuration changes you require in the default profiles. However, if the channel is assigned custom profiles, you must make the changes in those custom profiles.

# Community Repeater

In a community repeater, multiple talk groups use the same repeater but only hear calls that belong to their own talk group. A TB8100 base station with an 'Advanced Profiles and Task Manager' license can be set up to do this using CTCSS tones or DCS codes. Built-in signalling tone processing can handle up to 16 tones or codes. (The TB8100 also lets you send a reminder tone if a talk group is behind in payments. You can even stop the audio signal for groups that use a particular tone or code.)

To configure the TB8100 base station as a community repeater, you define a new signalling profile that configures the base station to decode the subaudible signalling of all the talk groups and to encode transmissions with the same signalling as was received:

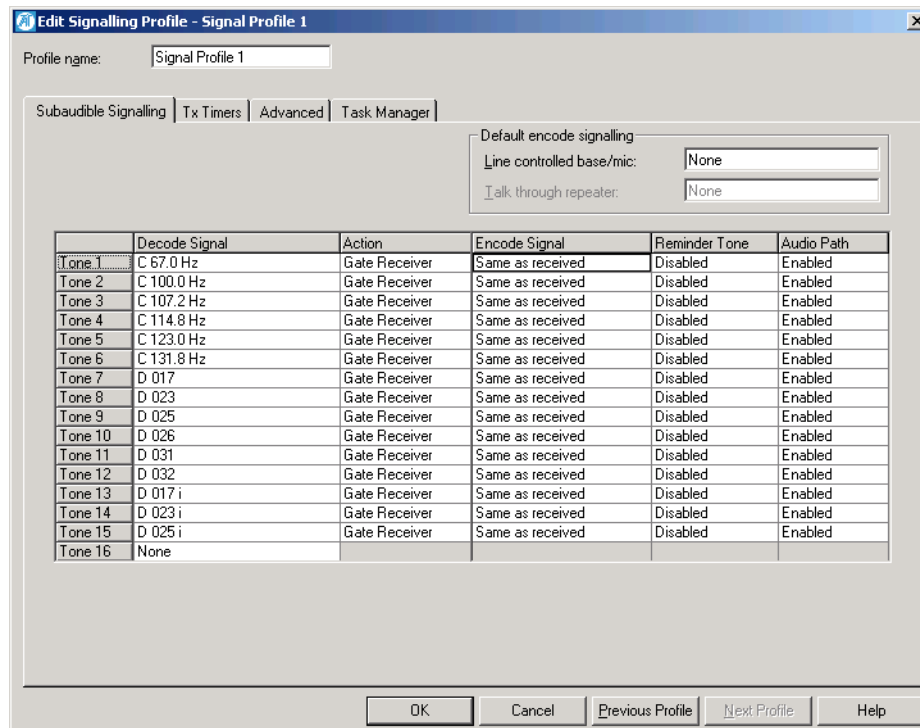

If desired, the signalling profile can easily be modified to encode transmissions with a different tone from the one received.

**Note** Do not use adjacent CTCSS tones. See the Service Kit online Help for more information.

## Linked Repeater

Linked repeaters can use TB8100 equipment for the links as well as for the repeater. Figure 2 shows an example. Two 50 W channels for the links and one 50 or 100 W channel for the broadcast repeater only occupy two 4 U subracks. For a link end configuration, only one subrack is needed (for channels A and x), provided Channel A does not use a 100 W power amplifier. Cabling connects the reciters' system interfaces, if necessary via a patching panel.

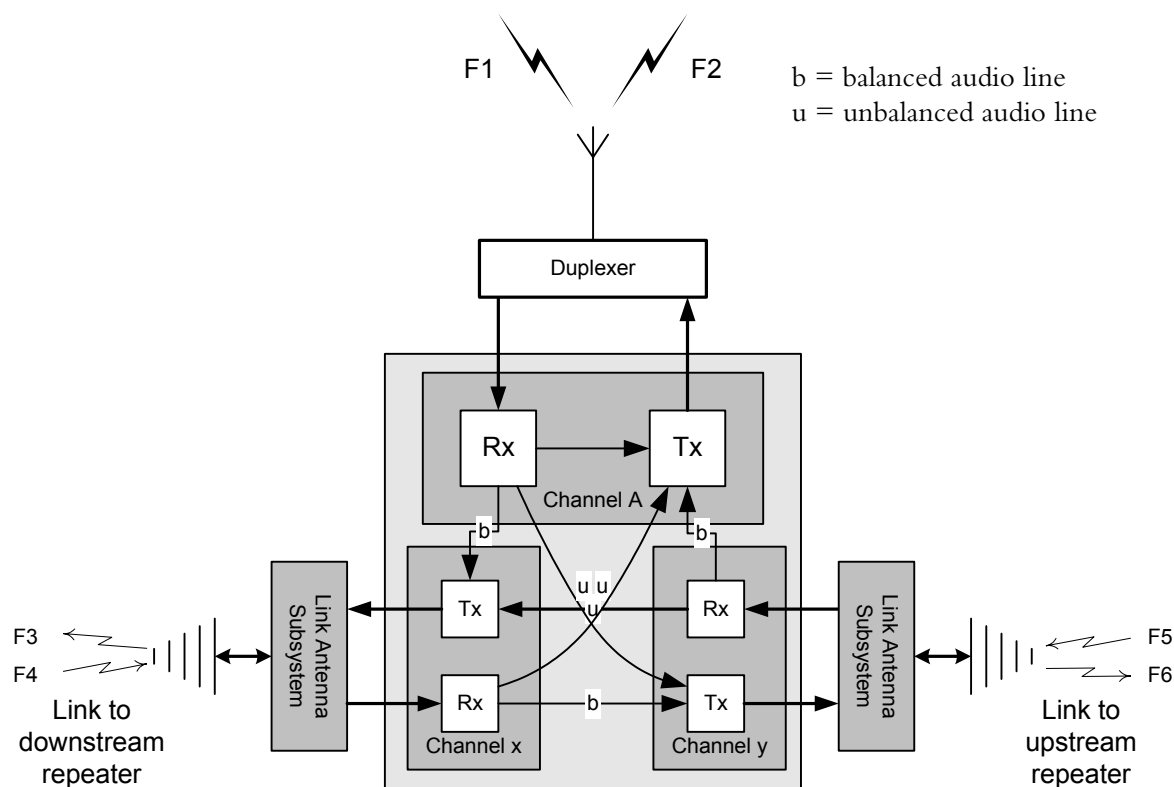

**Figure 2 Audio Connections for a Linked Repeater**

Channel A provides the basic repeater function while channels x and y provide a bidirectional link to adjacent repeater sites. Channel A receives on frequency F1 and re-transmits on F2. It therefore needs an audio link between receiver and transmitter.

Channels x and y receive audio from the adjacent repeaters for broadcasting and for passing along the link. Connections are needed between the channel x and y receivers and the Channel A transmitter and between the channel x and y transmitters and Channel A's receiver. The reciters therefore need to be fitted with a system interface that provides dual audio paths and you need to make up appropriate cabling for the connections

**Note** If the repeater site is a link end, there is only one link and Channel y is not needed.

## Connecting the TB8100s

For Channel A, the audio link from receiver to exciter is within the reciter. To create it, you simply configure the base station's audio path to include the link (see [“Standalone Talk-Through Repeater” on page 2](#)).

Each transmitter and receiver needs two audio connections. All standard interface boards (Standard 25, Standard 25 (Isolated Audio), and Standard 25 (isolated audio and E & M)) have dual audio paths, so you can use the balanced path for one connection and the unbalanced path for the other. Splitters and hybrids are not needed. However, you do need to connect the reciters via the DB25 connectors. The wiring is as follows:

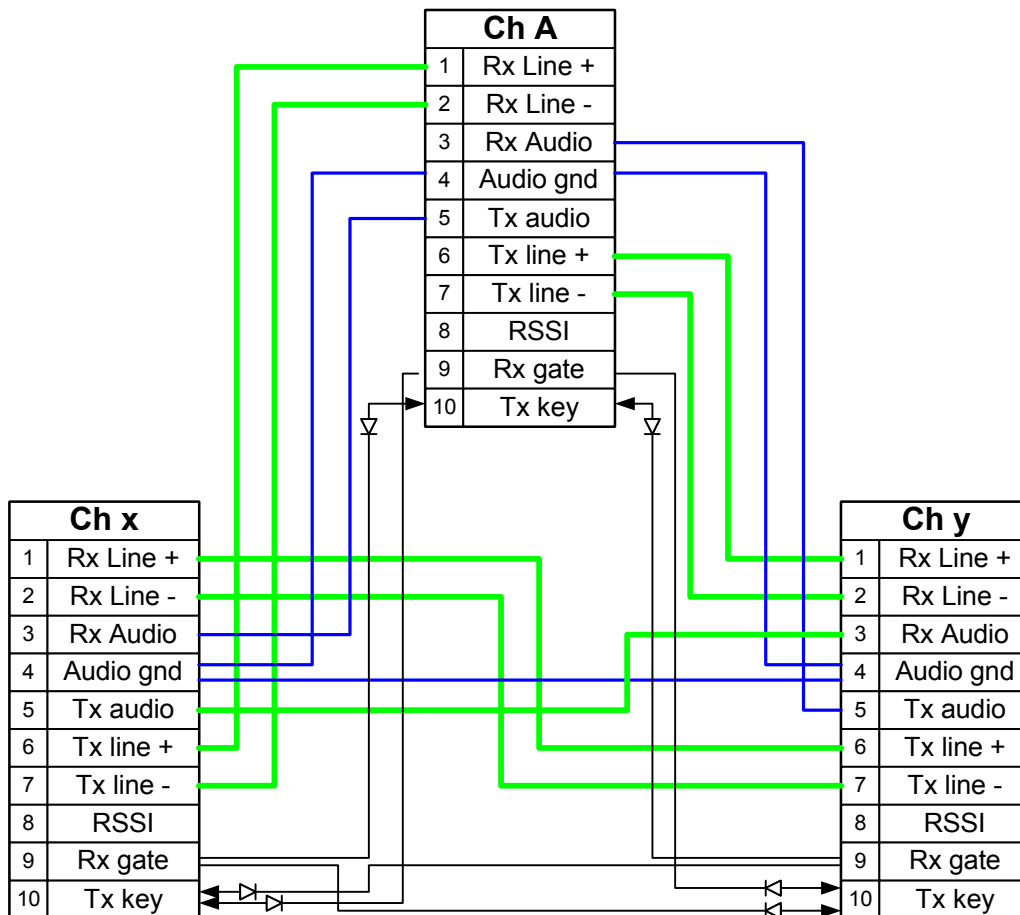

This drawing only shows pins 1-10 of the 25-pin connectors. Please note the use of diodes. For full pinout details, see the Installation manual. (Alternatively, use the Service Kit. Select Configure > Base Station > System Interface and select the correct system interface card to view pin assignments.)

## Issuing Authority

This TN was issued by: John Crossland  
Technical Publications Manager

## Publication History

Publication Date	Author
1 June 2003	L Chisholm

## Amendment Record

Publication Date	Page	Amendment
1 June 2003		First release

